

T-#2 CHIPPING HAMMER

T-#3 CHIPPING HAMMER

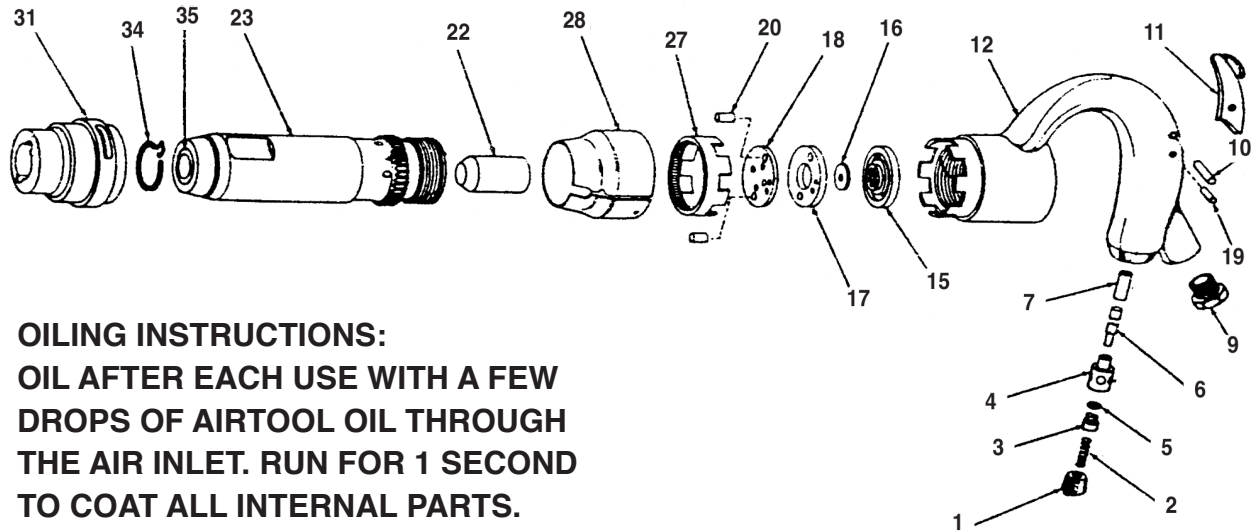



T-#4 CHIPPING HAMMER



OILING INSTRUCTIONS:

OIL AFTER EACH USE WITH A FEW DROPS OF AIRTOOL OIL THROUGH THE AIR INLET. RUN FOR 1 SECOND TO COAT ALL INTERNAL PARTS.

CHISELS ARE NOT INCLUDED WITH THE TOOL

- T-1101W2 : WIDE CHISEL 
- T-1103 : BUSHING TOOL 
- T-1108 : COLD CHISEL 
- T-1180 : MOIL POINT 

THESE CHISELS FIT OUR T-#24B, T-#34B, T-#44B, T-#2, T-#3 & T-#4 CHIPPING HAMMERS AS WELL AS ANY CHIPPING HAMMER THAT ACCEPTS .680 ROUND SHANK OVAL COLLAR CHISELS. FORGED STEEL. MADE IN USA. THE T-1103 IS 9 1/2" LONG. THE OTHER THREE CHISELS AVAILABLE IN 9", 12", OR 18" LENGTH.

USE 90 PSI MAXIMUM

REF #	PART #	DESCRIPTION	QTY	REF #	PART #	DESCRIPTION	QTY
1	#23401N3	PLUG	1	22	#222N3	PISTON FOR #2	1
2	#23402N3	SPRING	1		#322N3	PISTON FOR #3	1
3	#23403N3	THROTTLE VALVE	1		#422N3	PISTON FOR #4	1
4	#23404N3	BUSHING	1	23	#223N3	CYLINDER	1
5	#23405N3	O-RING	1		#323N3	CYLINDER	1
6	#23406N3	PIN	1		#423N3	CYLINDER	1
7	#23407N3	BUSHING	1	27	#23427N3	LOCK	1
9	#23409N3	AIR INLET	1	28	#23428N3	SHIELD-LOCK	1
10	#23410N3	PIN	1	31	#23431N3	SLEEVE-RETAINER	1
11	#23411N3	THROTTLE LEVER	1	34	#23434N3	LOCKCOIL SPRING	1
12	#23412N3	COMPLETE HANDLE (INCLUDES PARTS #1,2,3,4,5,6,7,9,10,11,12,19)	1	35	#23435N3	BUSHING (ROUND)	1
15	#23415N3	UPPER VALVE CASE	1		#2344B17H	BUSHING (HEX)	1
16	#23416N3	DISC VALVE	1			OPTIONAL ACCESSORIES	
17	#23417N3	LOWER VALVE	1		T-7516	QUICK CHANGE RETAINER	
18	#23418N3	CASE	1		T-#23450	HOSE SWIVEL 7/8-24	
19	#23419N3	PIN	1		T-#23451	HOSE SWIVEL 3/8" NPT	
20	#23420N3	PIN	2				

505 N. Railroad Ave. 33435
P.O. Box 1117 33425
Boynton Beach, FL

SEE MORE OF OUR CATALOG AT
www.taylorpneumatic.com

JUNE 2020 / ALL RIGHTS RESERVED / COPYRIGHT 2020

Ph. (561)732-1111
Fax. (561)731-4412
Toll Free (800) 805-8665